



REVERSIBLE ACTION SERIES

DESCRIPTION

Reversible Action Series Disc Plough has been specially developed as a land preparation solution for fields with gravel and crop stubbles. It is most suitable for crops of Wheat, Sugarcane, Corn, Rice and Millets. It has the ability to till all types of soil.



FEATURES

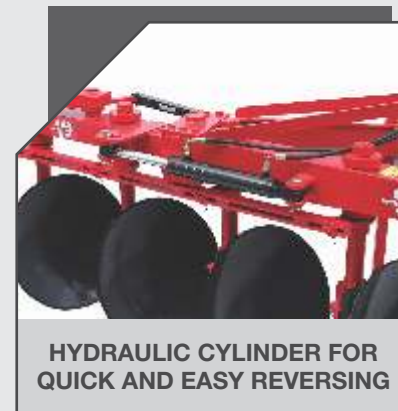
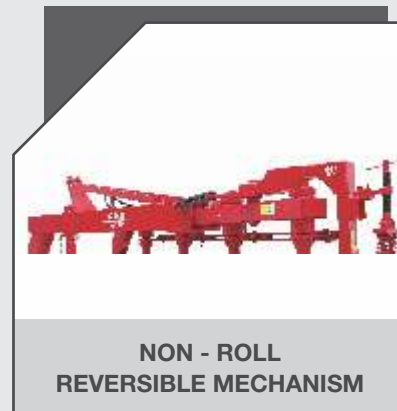

TECHNICAL SPECIFICATIONS

	Reversible Action Series		
	WT-RAS-02	WT-RAS-03	WT-RAS-04
Model	WT-RAS-02	WT-RAS-03	WT-RAS-04
No Of Disc	2	3	4
Type Of Disc	Plain		
Disc Diameter (mm / Inch)	660 / 26		
Working Width (mm / Inch)	500-550 / 19.7-21.6	875-925 / 34.4-36.4	1225-1250 / 48.2-49.2
Bearing Hubs	2	3	4
Drawbar Type	Heavy Duty		
Turnover Mechanism	Hydraulic		
Weight (Kg. / lbs Approx.)	440 / 970	550 / 1212	670 / 1477
Tractor Power (HP)	45-50	55-60	75-90

*Data and specifications are subject to change without any advance notice due to continuous product improvement and development.

BENEFITS AND ADVANTAGES

- ⦿ Quick and Easy reversing of plough using Selective Control Valve (SCV)
- ⦿ Improved uprooting, cutting and incorporation of stubbles and residue
- ⦿ Enhanced pulverization, less maintenance and better fuel efficiency